

EJECTION LATCHES OMITTED IN THIS VIEW FOR CLARITY

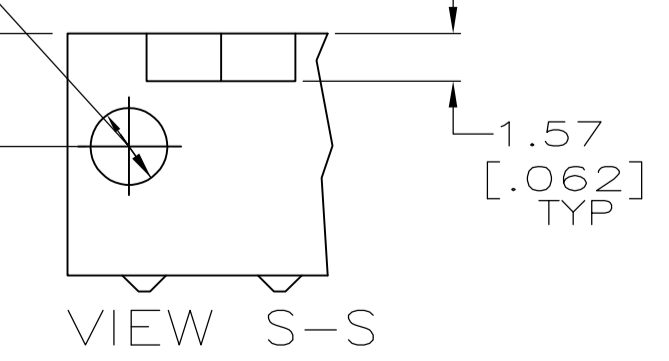
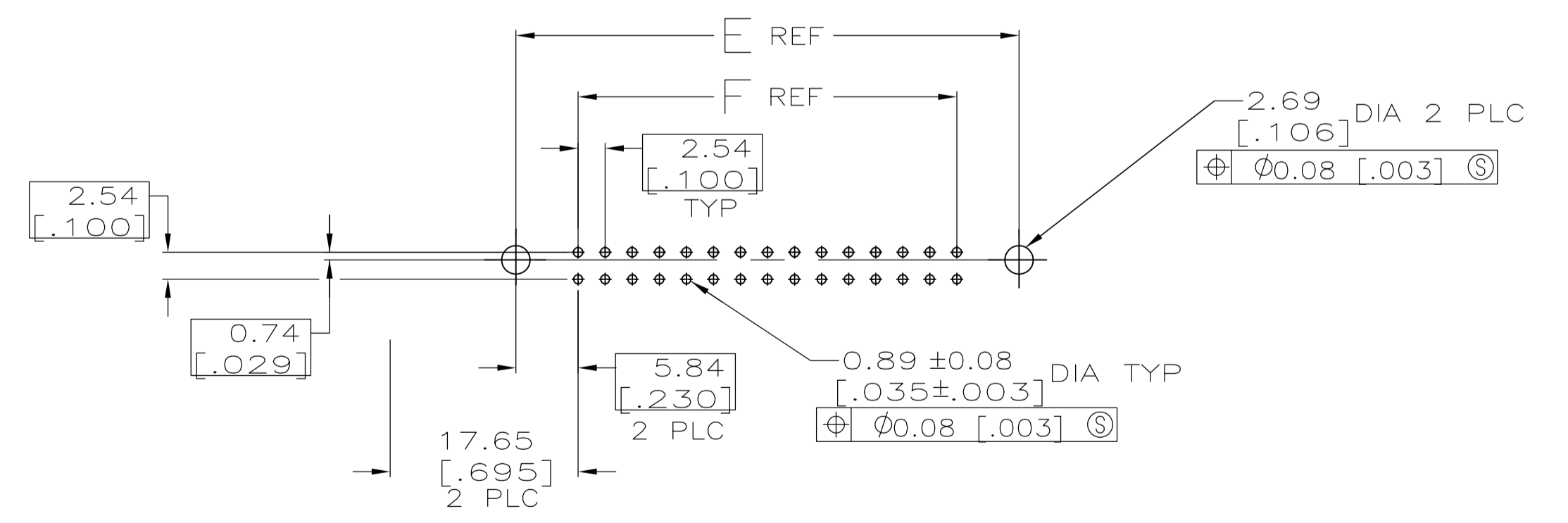
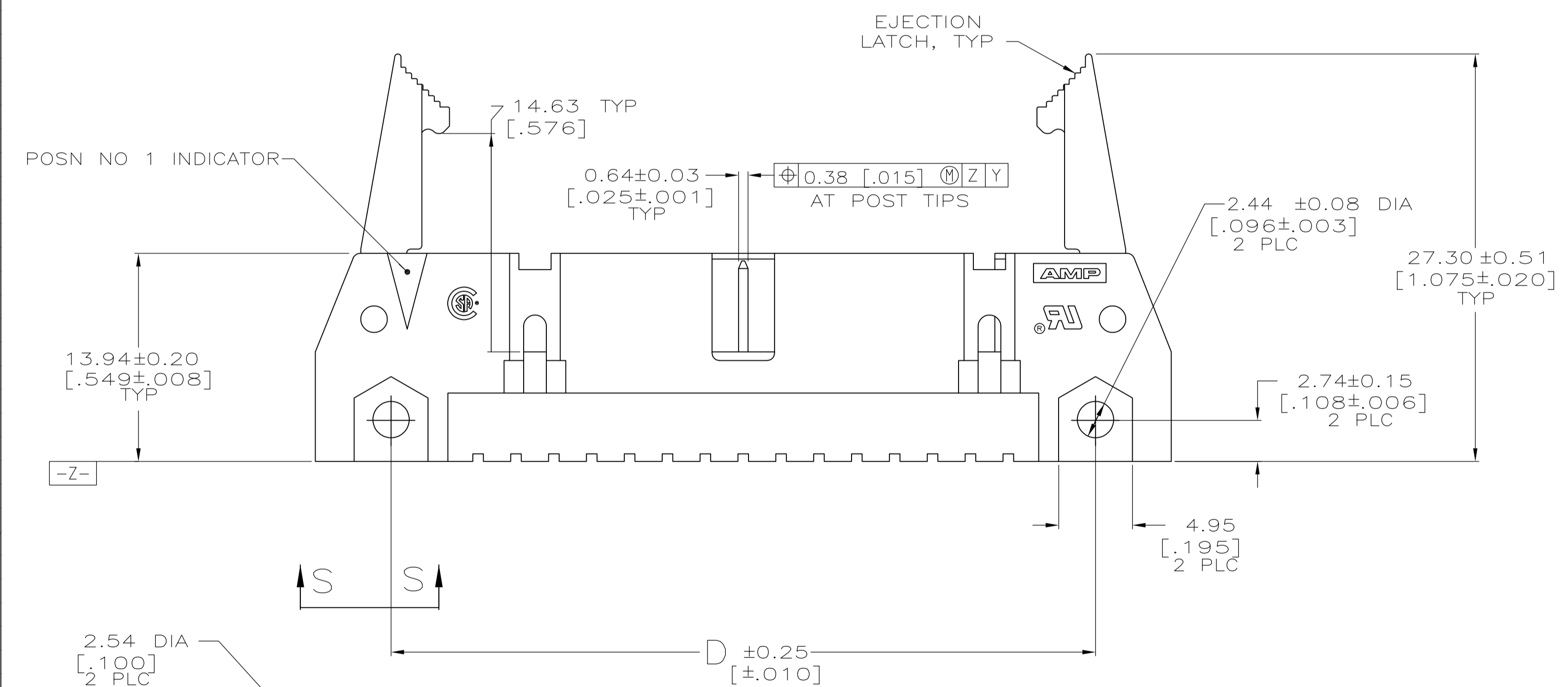
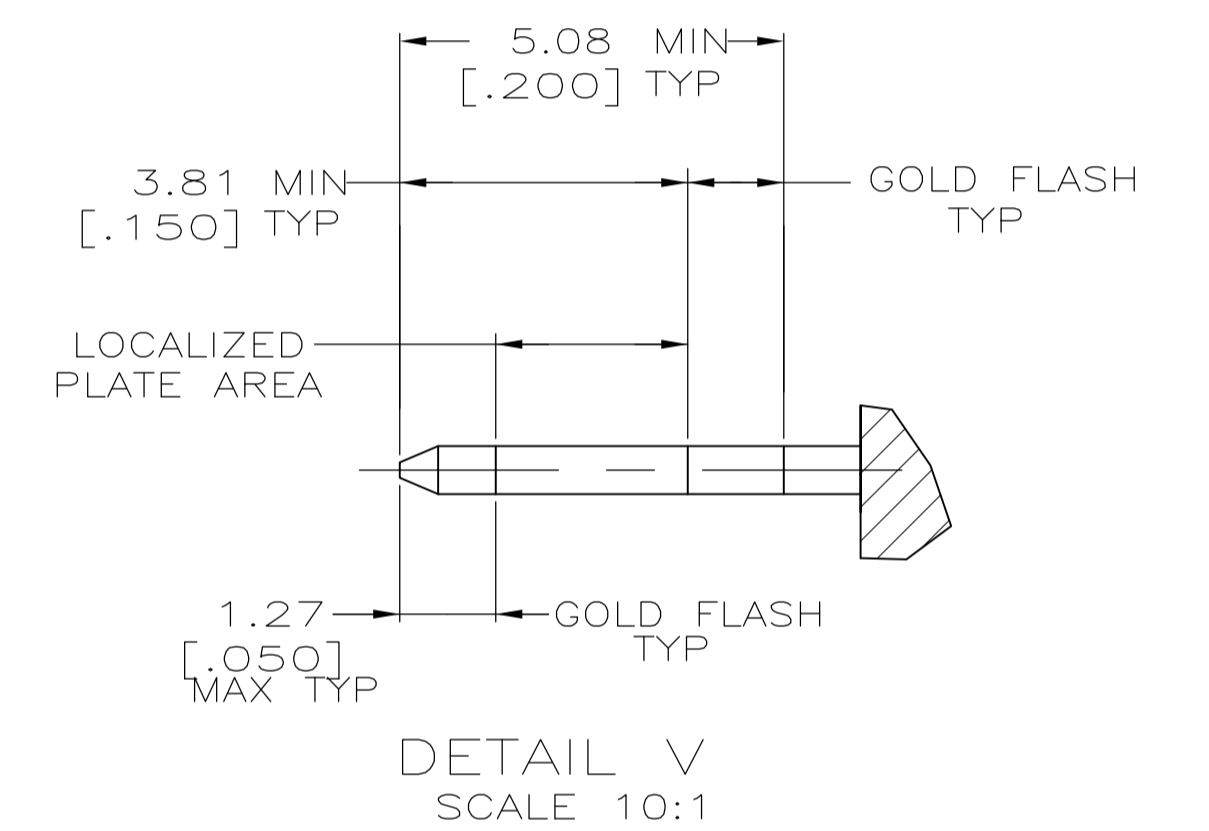
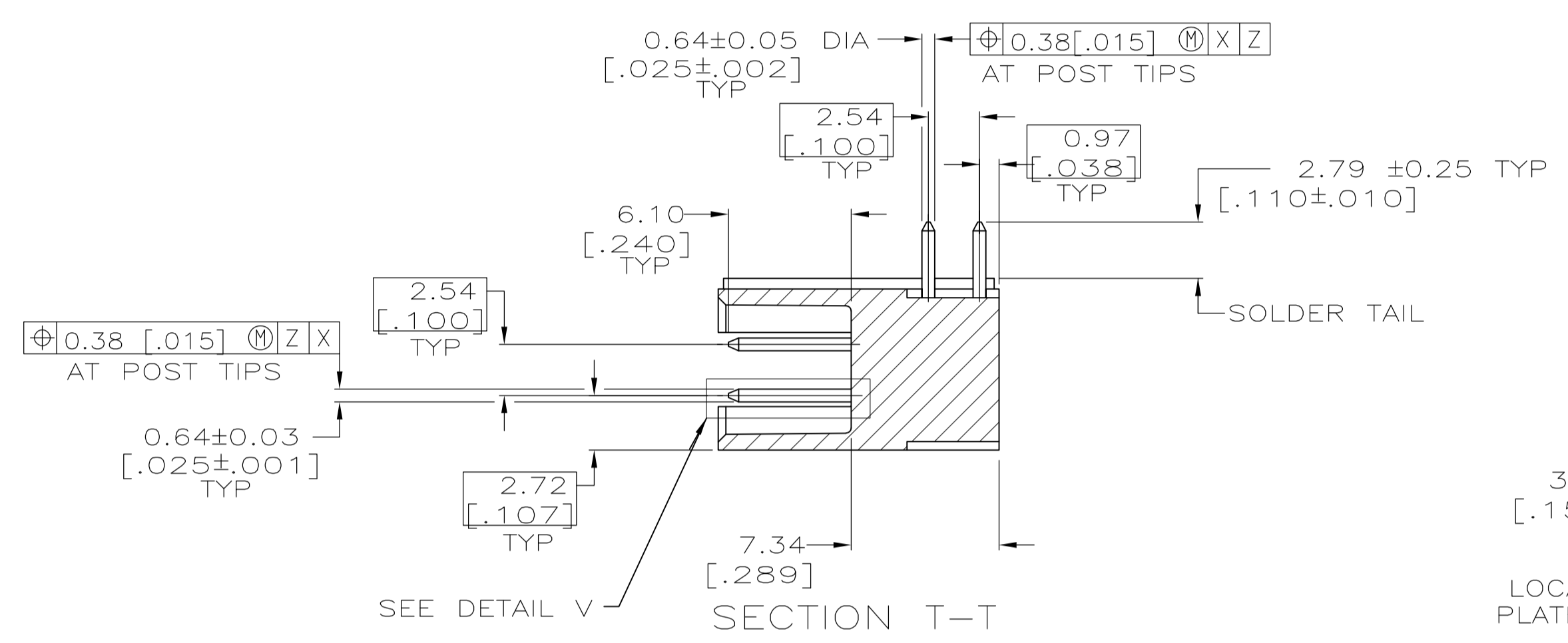
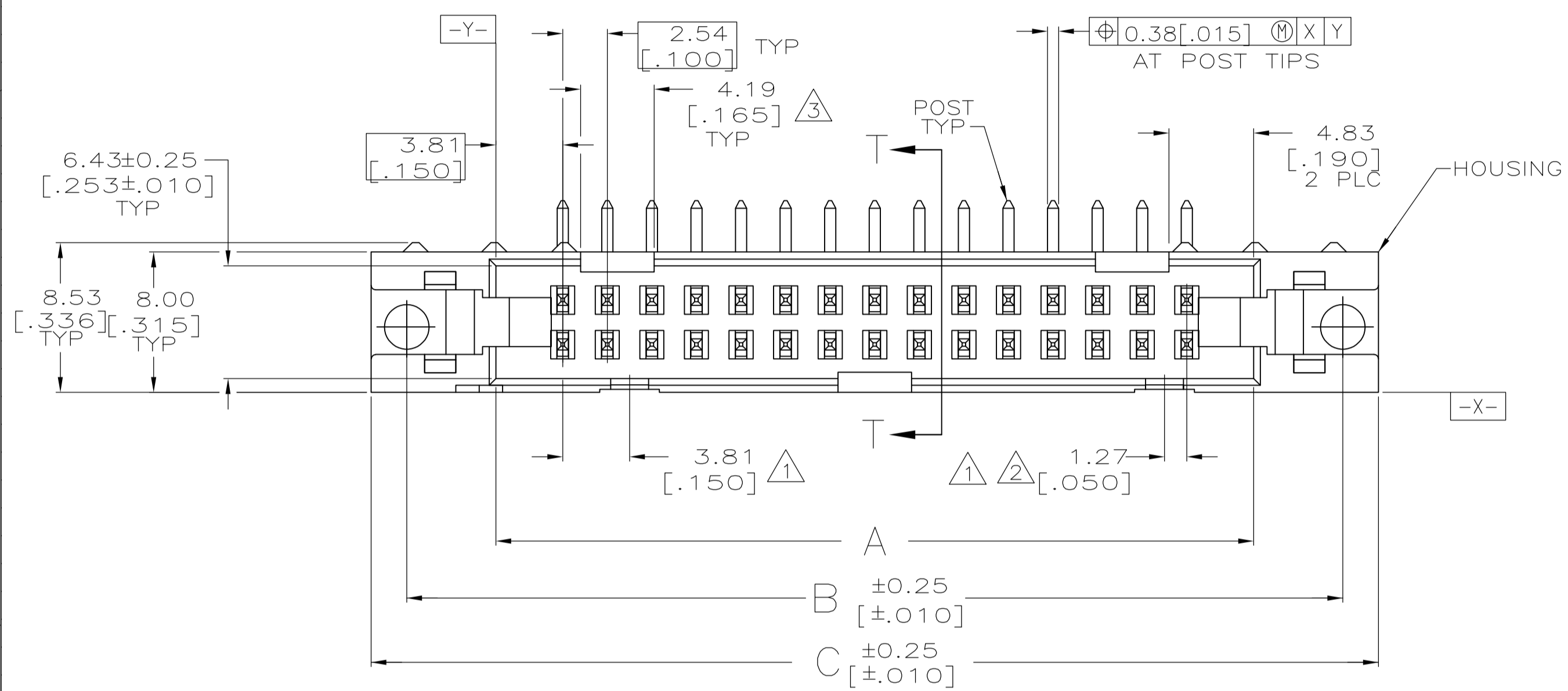

RECOMMENDED PC BOARD MOUNTING DIMENSIONS SCALE 2:1

| | | | | |
|--|--------------------|------------------------|------------------------------|--------------------|
| THIS DRAWING IS A CONTROLLED DOCUMENT. | | DIN 4-23-90 | Tyco Electronics Corporation | |
| DIMENSIONS: mm [INCHES] | | H. MOLL 11-28-90 | Harrisburg, PA 17105-3608 | |
| TOLERANCES UNLESS OTHERWISE SPECIFIED: | | R. STONE | Tyco Electronics | |
| 0 PLC ± - | 1 PLC ± ± | APVD - | NAME | |
| 2 PLC ± ± 0.13[.005] | 3 PLC ± ± | PRODUCT SPEC 108-40018 | | |
| 4 PLC ± ± | ANGLES ± ± | APPLICATION SPEC | | |
| MATERIAL SEE SHEET 2 | FINISH SEE SHEET 2 | SIZE A1 | CAGE CODE 00779 | DRAWING NO. 499786 |
| CUSTOMER DRAWING | | SCALE 4:1 | SHEET 1 OF 2 | REV H |

- ① COORDINATE DIMENSION APPLIES FROM BASIC LOCATION.
- ② 10 AND 14 POSITION SIZES CONTAIN ONLY ONE SLOT FOR SNAP-IN POLARIZER (MILITARY POLARIZATION) LOCATED AS SHOWN.
- ③ 10 POSITION SIZES CONTAIN ONLY ONE SLOT FOR DUAL POLARIZATION, LOCATED AS SHOWN.
- 4. RECOMMENDED PRINTED CIRCUIT BOARD THICKNESS IS 1.57 [.062].
- ⑤ DISTANCE REQUIRED BY EJECTION LATCHES IN THE OPEN POSITION.
- ⑥ POSTS:
 GOLD FLASH OVER
 0.38 μ m [.000015] MIN PALLADIUM-NICKEL PLATE ON THE LOCALIZED PLATE AREA,
 2.54 μ m [.000100] MIN TIN-LEAD PLATE ON THE SOLDER-TAIL,
 1.27 μ m [.000050] MIN NICKEL UNDERPLATE ON THE ENTIRE POST.
 OR
 0.38 μ m [.000015] MIN GOLD PLATE ON THE LOCALIZED PLATE AREA,
 2.54 μ m [.000100] MIN TIN-LEAD PLATE ON THE SOLDER-TAIL,
 1.27 μ m [.000050] MIN NICKEL UNDERPLATE ON THE ENTIRE POST.
- ⑦ MATERIAL:
 HOUSING: GLASS FILLED NYLON OR POLYESTER, 94V-0 RATED, BLACK.
 POSTS: BRASS.

| | | | | | | | | |
|----------|---------|---------|---------|---------|---------|---------|------------|-------------|
| OBSOLETE | 53.34 | 65.02 | 65.02 | 75.18 | 71.12 | 60.96 | 44 | 1-499786-3 |
| | [2.100] | [2.560] | [2.560] | [2.960] | [2.800] | [2.400] | | |
| | 78.74 | 90.42 | 90.42 | 100.58 | 96.52 | 86.36 | 64 | 1-499786-2 |
| | [3.100] | [3.560] | [3.560] | [3.960] | [3.800] | [3.400] | | |
| | 73.66 | 85.34 | 85.34 | 95.50 | 91.44 | 81.28 | 60 | 1-499786-1 |
| | [2.900] | [3.360] | [3.360] | [3.760] | [3.600] | [3.200] | | |
| | 60.96 | 72.64 | 72.64 | 82.80 | 78.74 | 68.58 | 50 | 1-499786-0 |
| | [2.400] | [2.860] | [2.860] | [3.260] | [3.100] | [2.700] | | |
| | 48.26 | 59.94 | 59.94 | 70.10 | 66.04 | 55.88 | 40 | 499786-9 |
| | [1.900] | [2.360] | [2.360] | [2.760] | [2.600] | [2.200] | | |
| | 40.64 | 52.32 | 52.32 | 62.48 | 58.42 | 48.26 | 34 | 499786-8 |
| | [1.600] | [2.060] | [2.060] | [2.460] | [2.300] | [1.900] | | |
| OBSOLETE | 35.56 | 47.24 | 47.24 | 57.40 | 53.34 | 43.18 | 30 | 499786-7 |
| | [1.400] | [1.860] | [1.860] | [2.260] | [2.100] | [1.700] | | |
| | 30.48 | 42.16 | 42.16 | 52.32 | 48.26 | 38.10 | 26 | 499786-6 |
| | [1.200] | [1.660] | [1.660] | [2.060] | [1.900] | [1.500] | | |
| | 27.94 | 39.62 | 39.62 | 49.78 | 45.72 | 35.56 | 24 | 499786-5 |
| | [1.100] | [1.560] | [1.560] | [1.960] | [1.800] | [1.400] | | |
| | 22.86 | 34.54 | 34.54 | 44.70 | 40.64 | 30.48 | 20 | 499786-4 |
| | [.900] | [1.360] | [1.360] | [1.760] | [1.600] | [1.200] | | |
| OBSOLETE | 17.78 | 29.46 | 29.46 | 39.62 | 35.56 | 25.40 | 16 | 499786-3 |
| | [.700] | [1.160] | [1.160] | [1.560] | [1.400] | [1.000] | | |
| | 15.24 | 26.92 | 26.92 | 37.08 | 33.02 | 22.86 | 14 | 499786-2 |
| | [.600] | [1.060] | [1.060] | [1.460] | [1.300] | [.900] | | |
| | 10.16 | 21.84 | 21.84 | 32.00 | 27.94 | 17.78 | 10 | 499786-1 |
| | [.400] | [.860] | [.860] | [1.260] | [1.100] | [.700] | | |
| | F | E | D | C | B | A | NO OF POSN | PART NUMBER |

| | | | | |
|--|------------|------------------|------------------------------|---------------|
| THIS DRAWING IS A CONTROLLED DOCUMENT. | | DIN 4-23-90 | Tyco Electronics Corporation | |
| DIMENSIONS: mm [INCHES] | | 11-28-90 | Harrisburg, PA 17105-3608 | |
| TOLERANCES UNLESS OTHERWISE SPECIFIED: | | APVD | NAME | |
| 0 PLC ± - | 1 PLC ± - | R.STONE | | |
| 2 PLC ± 0.13[.005] | 3 PLC ± - | PRODUCT SPEC | | |
| 4 PLC ± - | ANGLES ± - | 108-40018 | | |
| MATERIAL | | APPLICATION SPEC | | RESTRICTED TO |
| FINISH | | SIZE | CAGE CODE | DRAWING NO |
| ⑥ | | WEIGHT | A100779 | 499786 |
| CUSTOMER DRAWING | | SCALE | SHEET | REV |
| | | 4:1 | 2 OF 2 | |